

## C-more EA9 Series Touch Panels

# Quick Start Guide



### Safety Information



**WARNING:** To minimize the risk of potential safety problems, you should follow all applicable local and national codes that regulate the installation and operation of your equipment. These codes vary from area to area and it is your responsibility to determine which codes should be followed, and to verify that the equipment, installation, and operation are in compliance with the latest revision of these codes.

Equipment damage or serious injury to personnel can result from the failure to follow all applicable codes and standards. We do not guarantee the products described in this publication are suitable for your particular application, nor do we assume any responsibility for your product design, installation, or operation.

If you have any questions concerning the installation or operation of this equipment, or if you need additional information, please call technical support at 1-800-633-0405 or 770-844-4200.

This publication is based on information available at the time it was printed. At AutomationDirect.com® we constantly strive to improve our products and services, so we reserve the right to make changes to the products and/or publications at any time without notice and without obligation. This publication may also discuss features that may not be available in certain revisions of the product.

**ADVERTISSEMENT:** Afin de réduire au minimum le risque d'éventuels problèmes de sécurité, vous devez respecter tous les codes locaux et nationaux applicables régissant l'installation et le fonctionnement de votre équipement. Ces codes diffèrent d'une région à l'autre et, habituellement, évoluent au fil du temps. Il vous incombe de déterminer les codes à respecter et de vous assurer que l'équipement, l'installation et le fonctionnement sont conformes aux exigences de la version la plus récente de ces codes.

L'omission de respecter la totalité des codes et des normes applicables peut entraîner des dommages à l'équipement ou causer de graves blessures au personnel. Nous ne garantissons pas que les produits décrits dans cette publication conviennent à votre application particulière et nous n'assurons aucune responsabilité à l'égard de la conception, de l'installation ou du fonctionnement de votre produit.

Si vous avez des questions au sujet de l'installation ou du fonctionnement de cet équipement, ou encore si vous avez besoin de renseignements supplémentaires, n'hésitez pas à nous téléphoner au 770-844-4200.

Cette publication s'appuie sur l'information qui était disponible au moment de l'impression. À la société AutomationDirect, nous nous efforçons constamment d'améliorer nos produits et services. C'est pourquoi nous nous réservons le droit d'apporter des modifications aux produits ou aux publications en tout temps, sans préavis ni quelque obligation que ce soit. La présente publication peut aussi porter sur des caractéristiques susceptibles de ne pas être offertes dans certaines versions révisées du produit.

### Before you begin...

Minimum items required to create a working system:

- C-more EA9 Touch Panel - 6", 8", 10", 12" or 15" model
- C-more Programming Software, p/n EA9-PGMSW
- Personal computer - to run the C-more programming software
- C-more USB Programming Cable, p/n USB-CBL-AB15 or Ethernet connectivity between PC and Touch Panel
- Power source: C-more AC/DC Power Adapter, p/n EA-AC or a dedicated 12-24 VDC switching power supply
- Communications Cable (serial or Ethernet) - to connect the C-more Touch Panel to your controller



## 1 Unpack and Inspect

Inspect all equipment for completeness. If anything is missing or damaged, immediately call the AutomationDirect® returns department @ 1-800-633-0405.

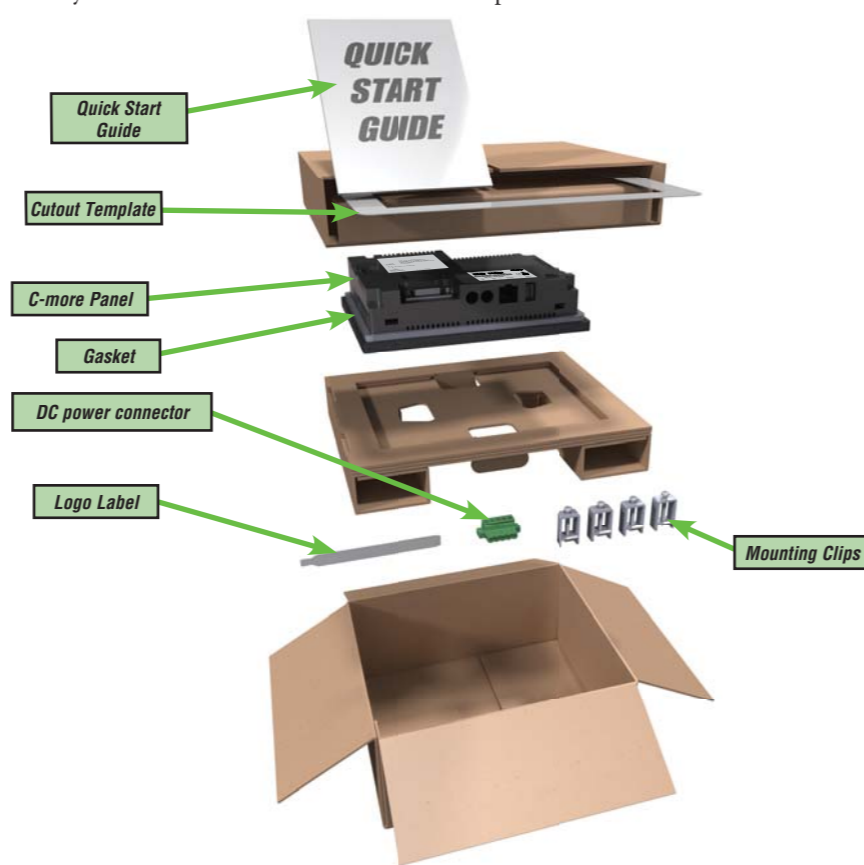

## 2 Install Optional Hardware Accessories

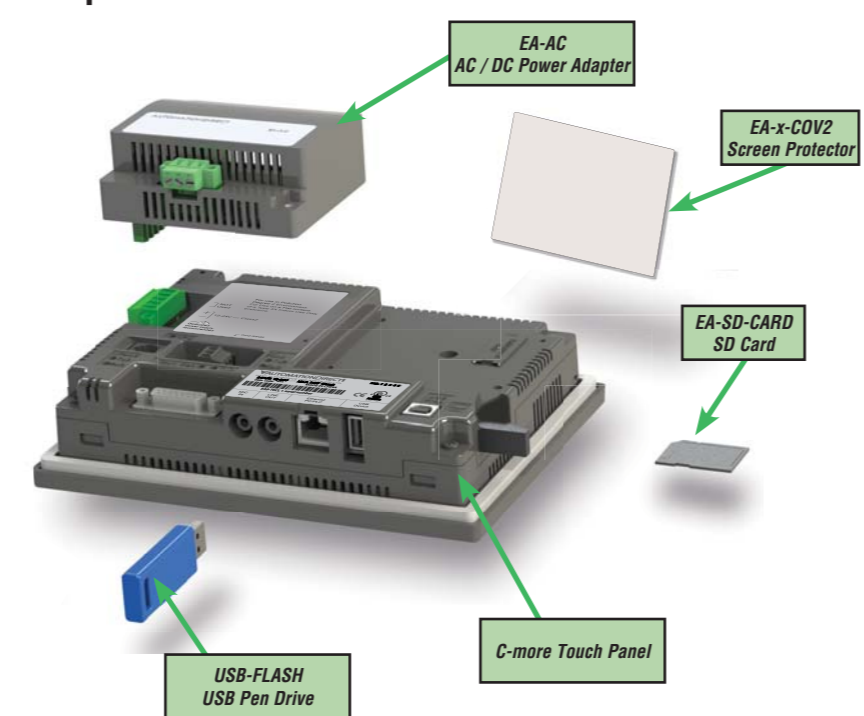

## 3 Available Communication Ports

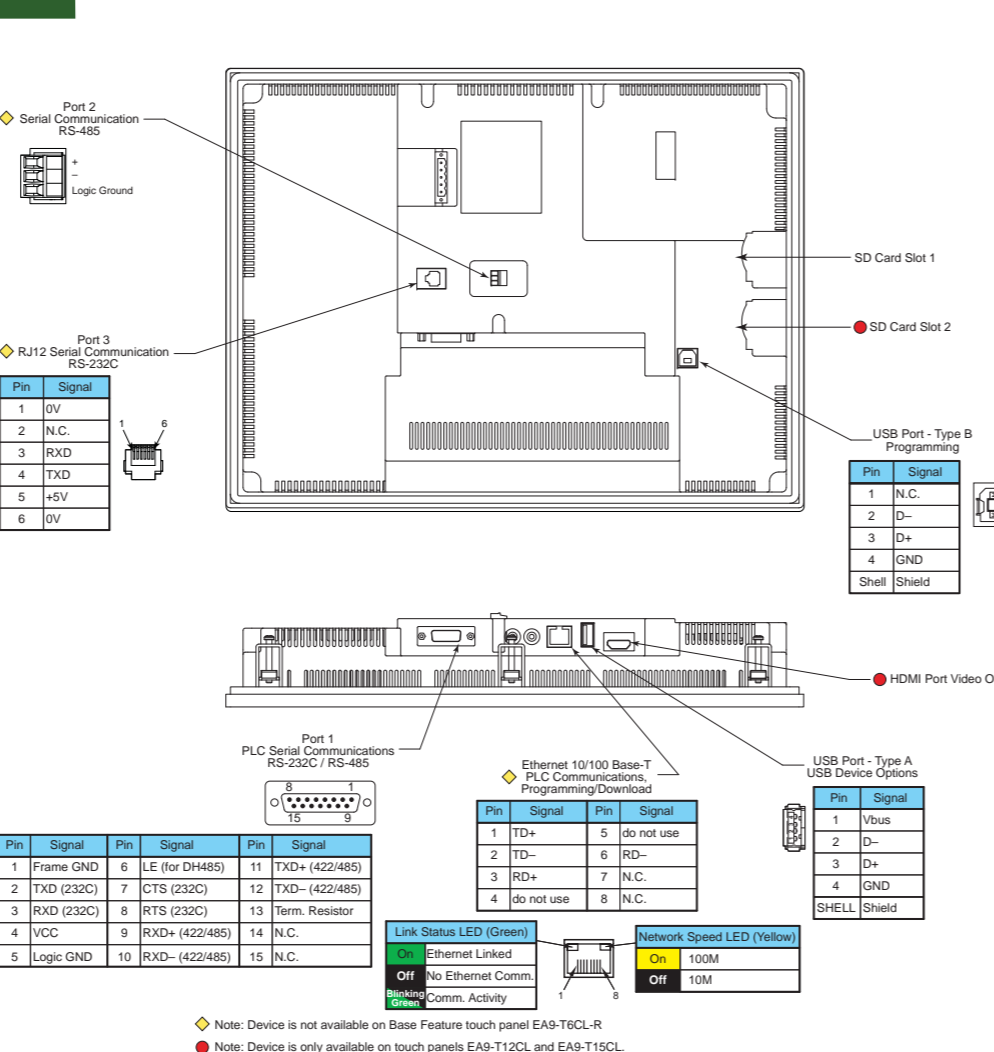

## 4 Install the Software and Develop a project

- Purchase the C-more programming software, EA9-PGMSW at AutomationDirect.com. EA9-PGMSW is available on CD or by direct download.
- Install EA9-PGMSW on your PC.
- Use the software to create a project.
- Download the project to the C-more panel from the software via Ethernet or USB cable or on USB memory or SD card



**Notes regarding Ethernet access to a C-more panel.**  
 If you intend to take advantage of the methods of remote access to the panel, including the web server, PC remote access, FTP, iPhone or iPad app, you need to consider the security exposure in order to minimize the risks to your process and your C-more panel.  
 Security measures may include password protection, changing the ports exposed on your network, including a VPN in your network, and other methods. Security should always be carefully evaluated for each installation.

## 5 Connect C-more Panel to Computer

- Connect a USB Programming Cable, such as p/n USB-CBL-AB15, from a USB type A port on the PC to the USB type B programming port on the C-more touch panel
- or connect the C-more touch panel and PC together either directly or via an Ethernet switch, and CAT5 Ethernet cables (full feature panels only)

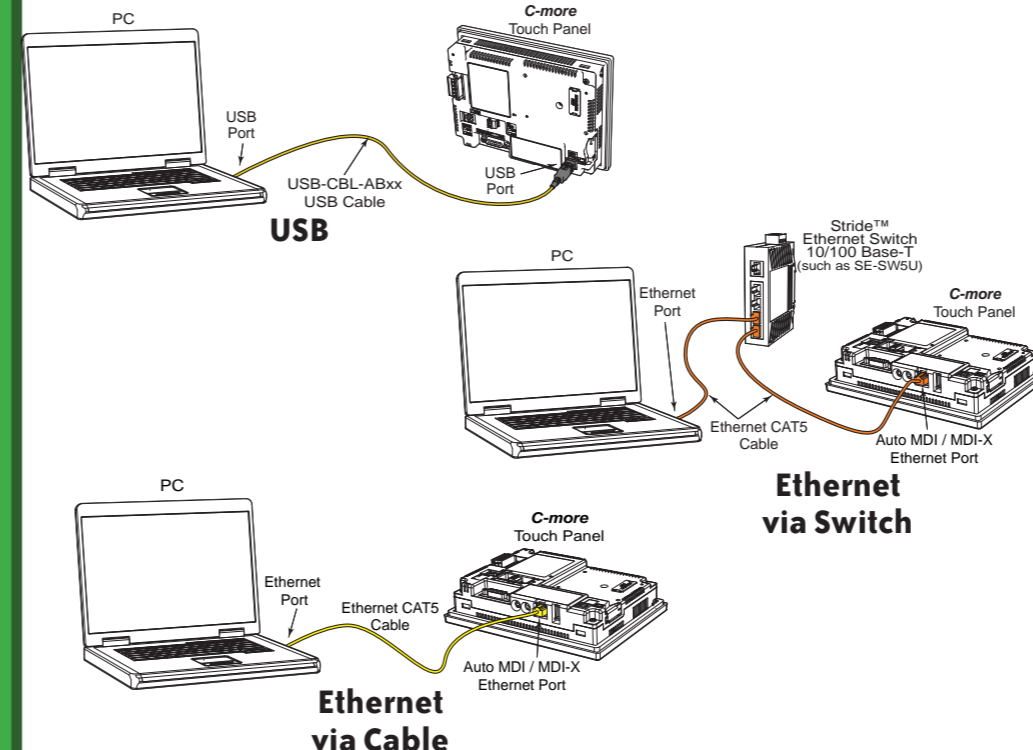

## 6 Provide Power to C-more Panel

Wire a dedicated 12-24 VDC power source to the DC connector on the rear of the C-more touch panel, include wiring the ground terminal to a proper equipment ground. The recommended power supply is AutomationDirect p/n: PSC24-060

- or install a C-more AC/DC Power Adapter, p/n EA-AC, to the rear of the touch panel and wire an AC voltage source of 100-240 VAC, 50/60Hertz, to its AC connector
- then turn on the power source and check the LED status indicators on the front and rear of the C-more touch panel for proper indication

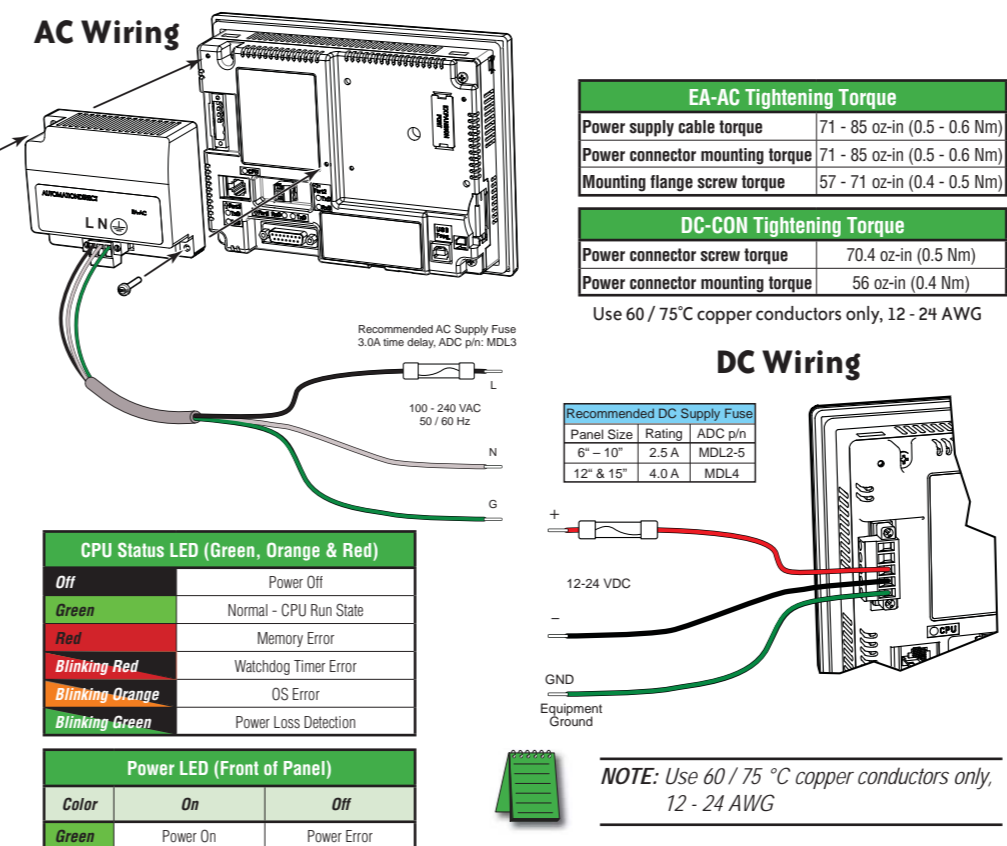

Specification	Power Specifications					
	EA9-T6CL-R	EA9-T6CL	EA9-T8CL	EA9-T10CL	EA9-T12CL	EA9-T15CL
Power Consumption	16.0W	18.0W	18.0W	18.0W	21.0W	29.0W
	1.30A @ 12 VDC 0.66A @ 24 VDC	1.50A @ 12 VDC 0.75A @ 24 VDC	1.50A @ 12 VDC 0.75A @ 24 VDC	1.50A @ 12 VDC 0.75A @ 24 VDC	1.75A @ 12 VDC 0.88A @ 24 VDC	2.40A @ 12 VDC 1.20A @ 24 VDC
Internal Fuse (non-replaceable)	4.0A			6.3A		

## 7 Access the C-more Panel Setup Screens

- Access the Main Menu of the touch panel setup screens by pressing the extreme upper left corner of the panel display area for three (3) seconds as shown below.
- Adjust the time and date for the panel by pressing the Setting button on the Main Menu, then press the Adjust Clock button on the Setting screen.
- Use the right pointing arrows for the time or date display to select the unit to change. Use the up and down arrows to increment or decrement the value for the selected unit.
- Press OK when done to accept the changes to the time and date that is retained in the touch panel's battery backed memory, or press Cancel to exit the Adjust Clock setup screen without making any changes.
- Press the Main Menu button on the Setting screen and then the Exit button on the Main Menu screen to return to the application screen.

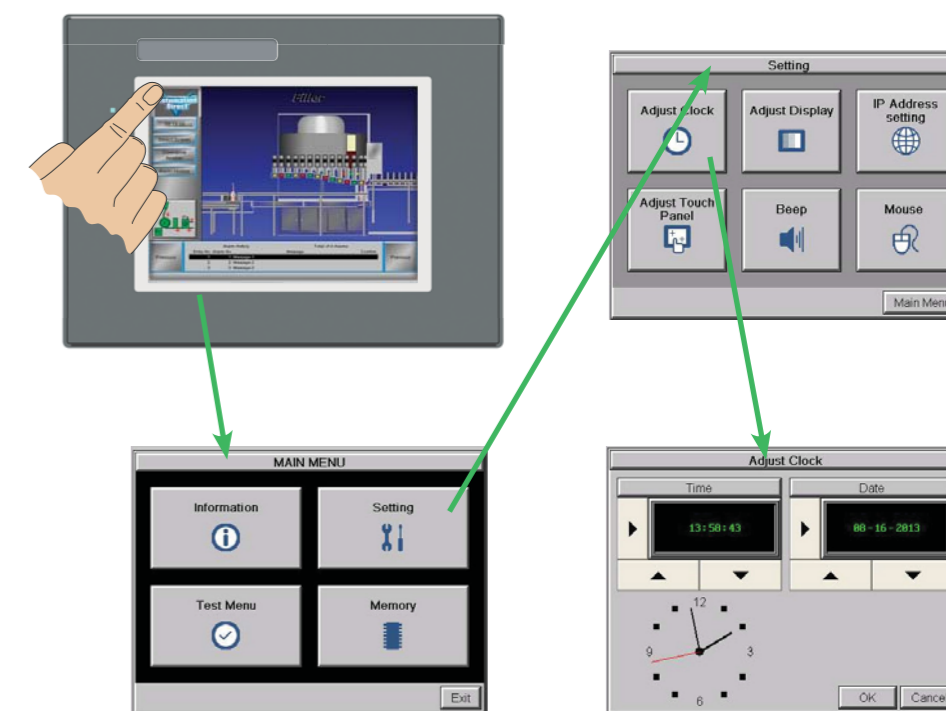

## 8 Connect the C-more Panel to a PAC or PLC

- Connect the serial communications cable between the C-more touch panel and the PLC
- or connect the C-more touch panel and PLC together via an Ethernet switch and Ethernet cables (full feature panels only)
- or use an Ethernet cable directly between the C-more Ethernet port and the PLC Ethernet port (full feature panels only)

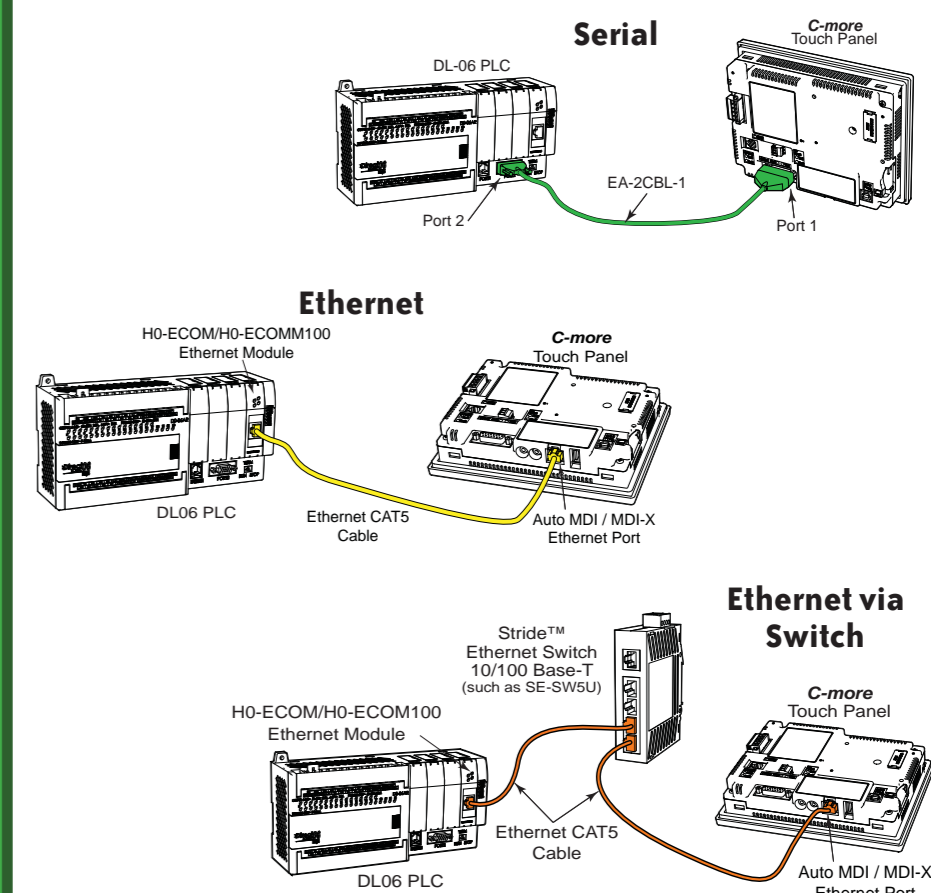

### Additional Help and Support

- For product support, specifications, and installation troubleshooting, a Hardware User Manual can be downloaded from the On-line Documentation area of the AutomationDirect Web site
- For software programming help, refer to the C-more Programming Software on-line embedded help.
- Refer to demos of the product at: [http://c-more.automationdirect.com/software/software\\_demo.html](http://c-more.automationdirect.com/software/software_demo.html)
- For additional technical support and questions, call our Technical Support team @ 1-800-633-0405 or 770-844-4200.



**Specifications**

Specifications								
Specification	Model	6" TFT color w/ base features	6" TFT color w/ full features	8" TFT color w/ full features	10" TFT color w/ full features	12" TFT color w/ full features	15" TFT color w/ full features	
Part Number		EA9-T6CL-R	EA9-T6CL	EA9-T8CL	EA9-T10CL	EA9-T12CL	EA9-T15CL	
Display Actual Size and Type		5.7" TFT color		8.4" TFT color	10.4" TFT color	12.1" TFT color	15.0" TFT color	
Display Viewing Area		4.54" x 3.40" [115.2 mm x 86.4 mm]		6.71" x 5.03" [170.4 mm x 127.8 mm]	8.31" x 6.24" [211.2 mm x 158.4 mm]	9.69" x 7.26" [246.0 mm x 184.5 mm]	11.97" x 8.98" [304.1 mm x 228.0 mm]	
Weight		1.56 lb (710g)	1.59 lb (720g)	2.93 lb (1330g)	4.19 lb (1900g)	4.89 lb (2200g)	6.50 lb (2950g)	
Screen Pixels		320 x 240 (QVGA)		800 x 600 (SVGA)		1024 x 768 (XGA)		
Display Brightness		280 nits (typ)		310 nits (typ)	280 nits (typ)			
LCD Panel Dot Pitch		0.18 mm x 0.18 mm		0.213 mm x 0.213 mm	0.264 mm x 0.264 mm	0.3075 mm x 0.3075 mm	0.297 mm x 0.297 mm	
Color Scale		65,536 colors						
Backlight Average Lifetime*		50,000 hours @ 25 °C						
Touch Panel Type		Four-wire analog resistive						
Project Memory		26 MB			82 MB			
Number of Screens		Up to 999 screens – limited by project memory						
Realtime Clock		Realtime Clock Built into panel, backed up for 30 days at 25°C						
Calendar - Month / Day / Year		Yes - monthly deviation 60 sec (Reference)						
Serial Port 1		15-pin D-sub female - RS232C, RS-422/485						
Serial Port 2		N/A					3-wire terminal block - RS-485	
Serial Port 3		N/A					RJ-12 modular jack - RS-232C	
USB Port - Type B		USB 2.0 High speed (480 Mbps) Type B - Download/Program						
USB Port - Type A		USB 2.0 High speed (480 Mbps) Type A -for USB device options						
Ethernet Port		N/A					Ethernet Port Ethernet 10/100 Base-T, auto MDI/MDI-X	
Audio Line Out		N/A					3.5 mm mini jack – requires amplifier and speaker(s)	
Mic In		N/A					3.5 mm mini jack	
SD Card Slot		1 slot supports max 2 GB (SD), max 32 GB (SDHC)			2 slots support max 2 GB (SD), max 32 GB (SDHC)			
HDMI Out		N/A			Yes			
Supply Power		12-24 VDC, or use the AC/DC Power Adapter, EA-AC, to power the touch panel from a 100-240 VAC, 50/60 Hz power source. Reverse Polarity Protected						
Power Consumption		16.0W 1.30A @ 12 VDC 0.66A @ 24 VDC	18.0W 1.50A @ 12 VDC 0.75A @ 24 VDC	18.0W 1.50A @ 12 VDC 0.75A @ 24 VDC	21.0W 1.75A @ 12 VDC 0.88A @ 24 VDC	29.0W 2.40A @ 12 VDC 1.20A @ 24 VDC		
Internal Fuse (non-replaceable)		4.0A			6.3A			
Operating Temperature		0 to 50 °C (32 to 122 °F); Maximum surrounding air temperature rating: 50 °C (122 °F) IEC 60068-2-14 (Test Nb, Thermal Shock)						
Storage Temperature		-20 to +60 °C (-4 to +140 °F) IEC 60068-2-1 (Test Ab, Cold) IEC 60068-2-2 (Test Bb, Dry Heat) IEC 60068-2-14 (Test Na, Thermal Shock)						
Humidity		5-95% RH (non-condensing)						
Environment		For use in Pollution Degree 2 environment, no corrosive gases permitted						
Noise Immunity		NEMA ICS3-304 (EN61131-2) RFI, (145MHz, 440MHz, 10W @ 10cm) Impulse 1000V @ 1ms pulse EN61000-4-2 (ESD), EN61000-4-3 (RFI), EN61000-4-4 (FTB), EN61000-4-5 (Serge), EN61000-4-6 (Conducted), EN61000-4-8 (Power frequency magnetic field immunity)						
Withstand Voltage		1000 VAC, 1 min. (FG to Power supply)						
Insulation Resistance		> 10M ohm @ 500V DC (FG to Power supply)						
Vibration		IEC60068-2-6 (Test Fc)						
Shock		IEC60068-2-27 (Test Ea)						
Emission		EN55011 Class A (Radiated RF emission)						
Enclosure		NEMA 250 type 4/4X indoor use only UL50 type 4X indoor use only IP-65 indoor use only (When mounted correctly)						
Agency Approvals		UL508, E157382 CE (EN61131-2), RoHS (2011/65/EU) CUL Canadian C22.2						

\* NOTE: The backlight average lifetime is defined as the average usage time it takes before the brightness becomes 50% of the initial brightness. The lifetime of the backlight depends on the ambient temperature. The lifetime will decrease under low or high temperature usage.

UL Satisfaction Ratings	
Model Number	Input Ratings
EA9-T6CL-R	12 - 24 VDC, Class 2, Maximum 16.0W
EA9-T6CL	
EA9-T8CL	
EA9-T10CL	12 - 24 VDC, Class 2, Maximum 18.0W
EA9-T12CL	12 - 24 VDC, Class 2, Maximum 21.0W
EA9-T15CL	12 - 24 VDC, Class 2, Maximum 29.0W

Terminal connecting wire size 12 - 24 AWG  
Connecting torque 71 - 85 oz-in (5 - 7 lbf-in) (0.5 - 0.6 Nm)  
Maximum surrounding air temperature rating, 50°C  
For use in Pollution Degree 2 environment  
All interface ports are intended to be directly connected to an isolated secondary circuit  
For use on a flat surface of a type 4X Indoor Use Only enclosure

**C-more Panel Dimensions**

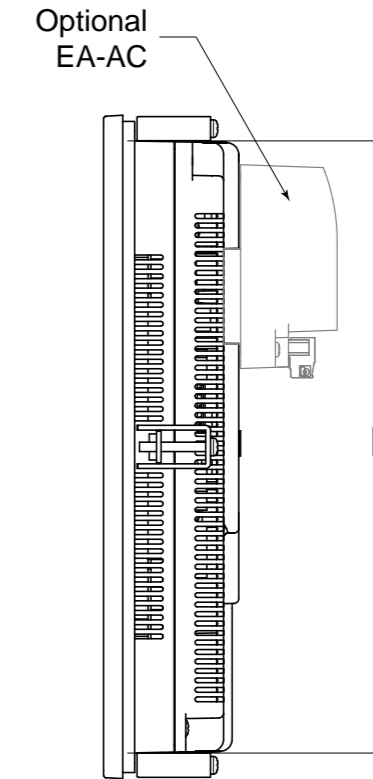
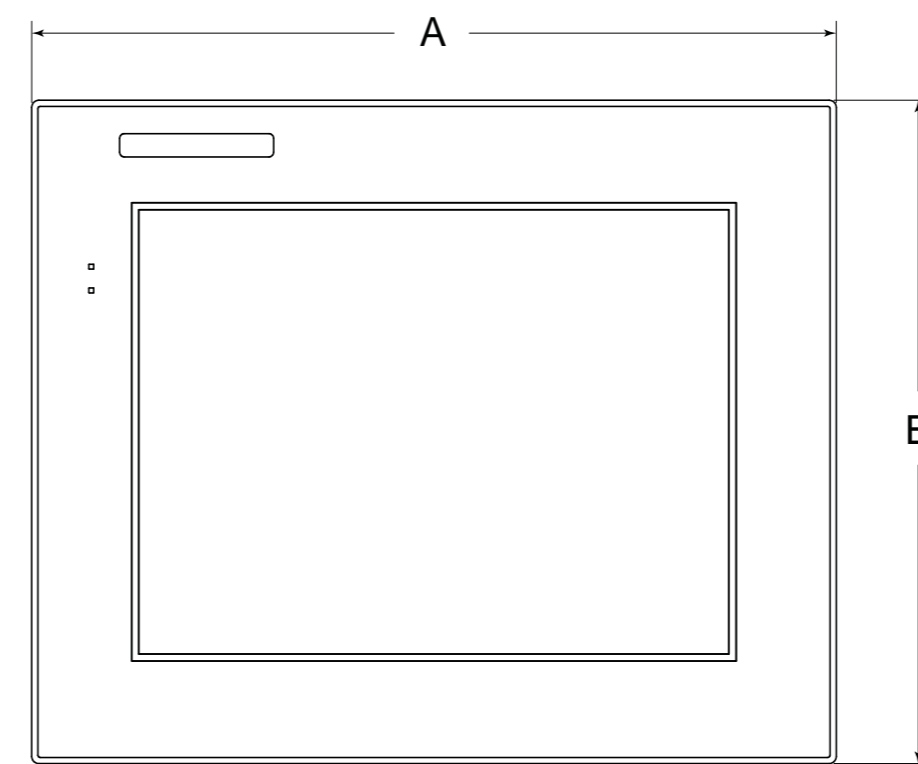
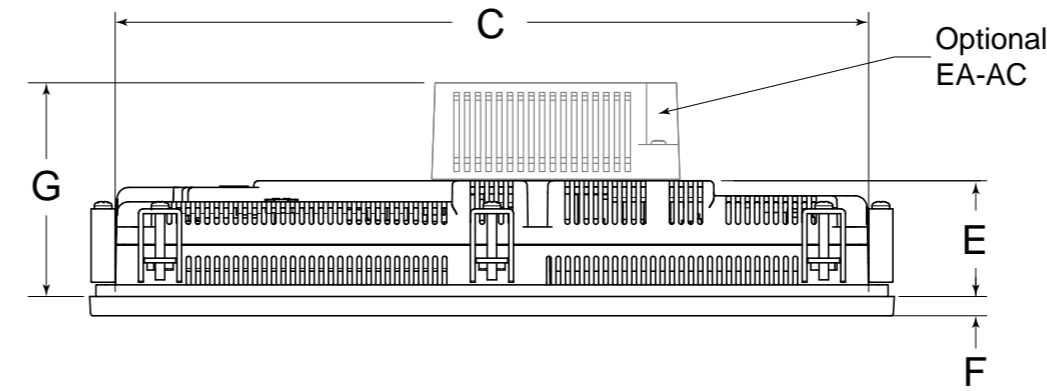

Panel Dimensions							
Model Number	A	B	C	D	E	F	G
EA9-T6CL-R	8.08 [205.2]	6.13 [155.8]	7.40 [188.0]	5.46 [138.7]	1.58 [40.1]	0.32 [8.1]	2.99 [75.9]
EA9-T6CL	8.08 [205.2]	6.13 [155.8]	7.40 [188.0]	5.46 [138.7]	1.58 [40.1]	0.32 [8.1]	2.99 [75.9]
EA9-T8CL	9.87 [250.7]	7.69 [195.4]	9.19 [233.4]	7.01 [178.1]	2.09 [53.1]	0.32 [8.1]	3.51 [89.2]
EA9-T10CL	12.52 [318.0]	9.53 [242.1]	11.84 [300.7]	8.84 [224.5]	1.93 [49.0]	0.32 [8.1]	3.51 [89.2]
EA9-T12CL	13.37 [339.6]	11.02 [280.0]	12.52 [318.0]	10.17 [258.3]	1.93 [49.0]	0.32 [8.1]	3.35 [85.1]
EA9-T15CL	15.75 [400.0]	12.09 [307.2]	14.88 [378.0]	11.20 [284.5]	1.93 [49.0]	0.32 [8.1]	3.35 [85.1]

Units: Inches [mm]

**C-more Panel Mounting**

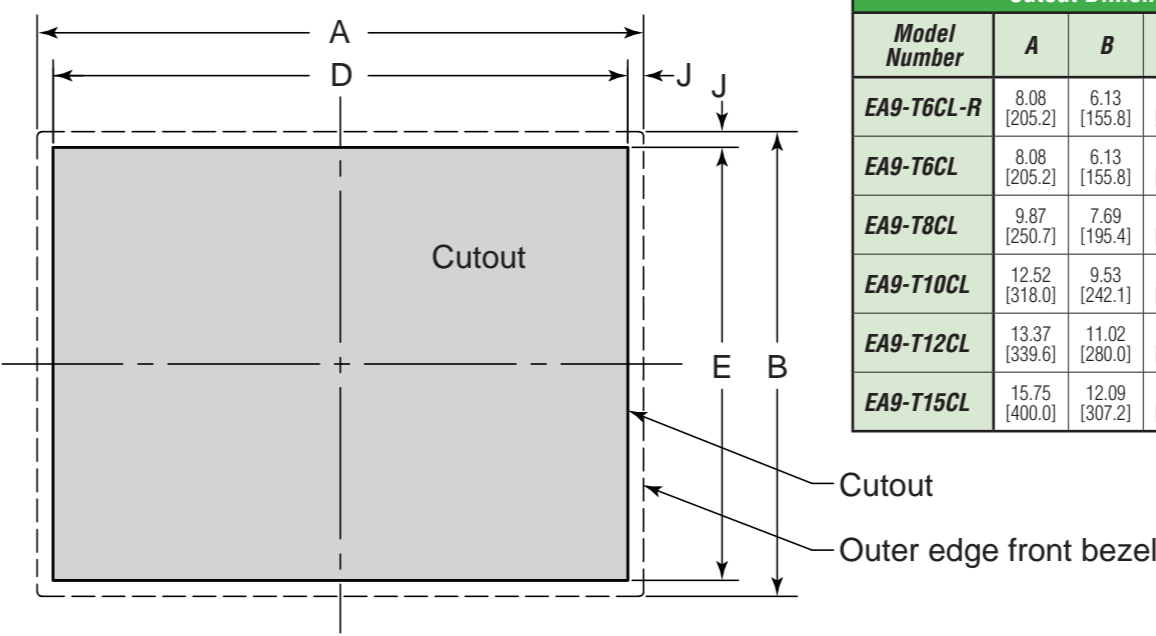

Cutout Dimensions					
Model Number	A	B	D	E	J
EA9-T6CL-R	8.08 [205.2]	6.13 [155.8]	7.46 [189.5]	5.51 [140.0]	0.31 [7.9]
EA9-T6CL	8.08 [205.2]	6.13 [155.8]	7.46 [189.5]	5.51 [140.0]	0.31 [7.9]
EA9-T8CL	9.87 [250.7]	7.69 [195.4]	9.25 [235.0]	7.07 [179.6]	0.31 [7.9]
EA9-T10CL	12.52 [318.0]	9.53 [242.1]	11.90 [302.3]	8.91 [226.3]	0.31 [7.9]
EA9-T12CL	13.37 [339.6]	11.02 [280.0]	12.57 [319.3]	10.22 [259.6]	0.40 [10.2]
EA9-T15CL	15.75 [400.0]	12.09 [307.2]	14.93 [379.2]	11.27 [286.3]	0.41 [10.4]

Units: Inches [mm]

**Mounting Bracket Locations**

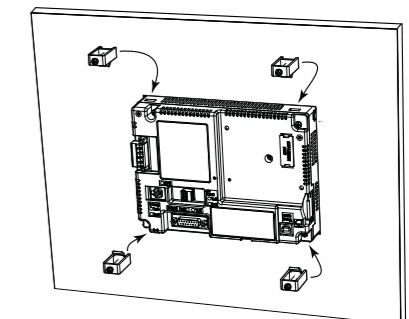

EA9-T6CL, EA9-T6CL-R and EA9-T8CL (4 places)

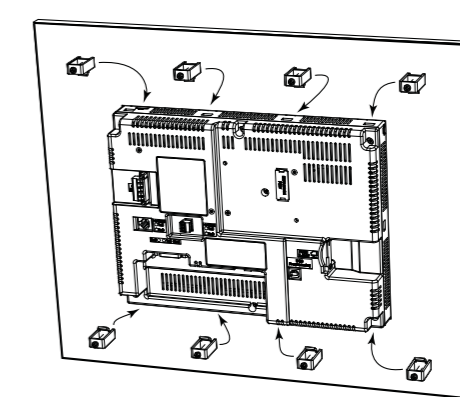

EA9-T10CL (8 places)

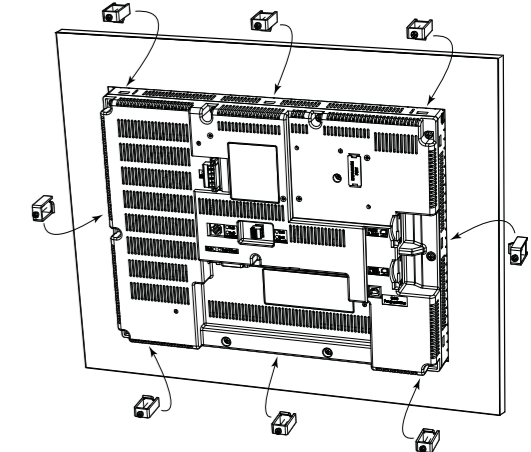

EA9-T12CL and EA9-T15CL (8 places)

**Additional Installation Information**

- Clearance – The mounting clearances when installing the touch panel in an enclosure or cabinet shall be minimum of 4 inches from the top, bottom and sides and 1.72 inches from the rear.
- Derating – If EA9-T15CL is mounted off the vertical plane facing upward, the temperature shall be derated as shown below. There is no derating if EA9-T15CL is mounted off the vertical plane facing downward. Other panels may be mounted at any angle without derating consideration.

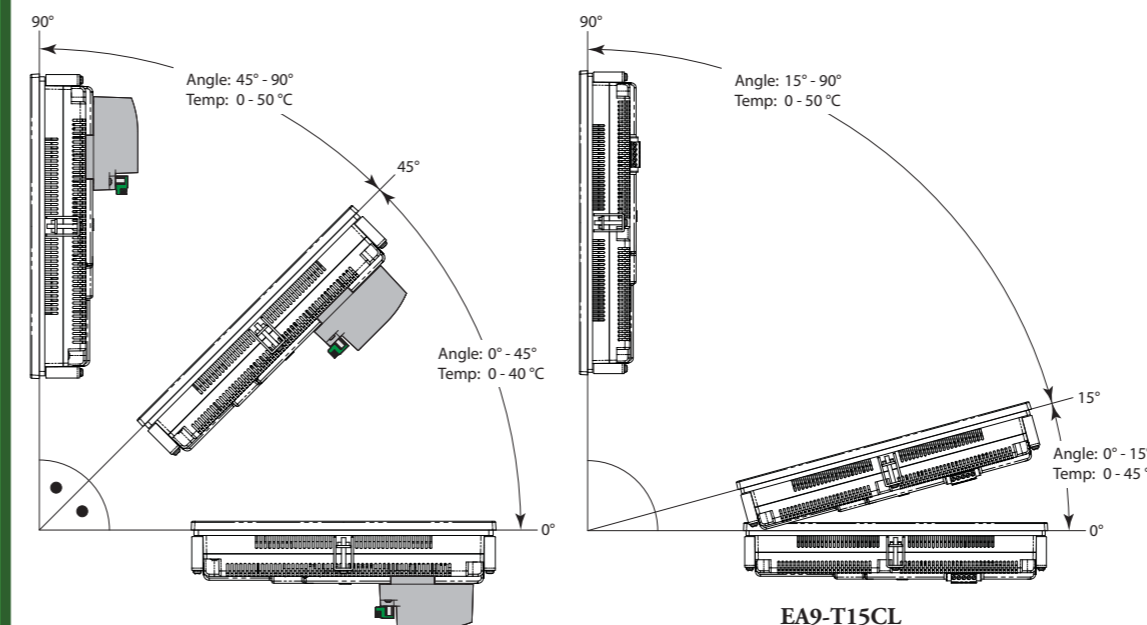

EA9-T15CL with EA-AC